

APPARATUS FOR GENERATING FUSION REACTIONS

Robert L. Hirsch and Gene A. Meeks, Fort Wayne, Ind.,

Assignors to International Telephone and Telegraph Corporation,

Nutley, NJ, a corporation of Delaware

Filed April. 24, 1968. Ser. No. 723,825

int. Ci. G21b

ABSTRACT OF THE DISCLOSURE

A generally spherical or cylindrical anode has concentrically positioned therein an ion-source grid and a cathode, both generally spherical or cylindrical and permeable to charged particle flow. The grid is interposed between the anode and cathode, and the cathode is hollow, defining a volume centrally located with respect to all three of the anode, grid and cathode electrodes. This volume is free of tangible structure. A fusion-reacting gas is contained within the volume. A voltage is applied to the three electrodes for establishing a first electric field in the space between the anode and grid and a second electric field in the space between the grid and the cathode. The ion-source grid is at a positive potential with respect to both the anode and cathode. The second electric field is of sufficient magnitude to impart fusion-reacting energies to particles of positive charge introduced into the second space. A thermionic cathode is positioned in the first space between the anode and grid.

BACKGROUND OF THE INVENTION

Field of the invention

This invention relates to apparatus for generating fusion reactions and more particularly to apparatus for producing controlled nuclear-fusion reactions with facility and reliability.

DESCRIPTION OF THE PRIOR ART

In Farnsworth Pat. No. 3,258,402, issued June 28, 1966, as well as Farnsworth Pat. No. 3,386,883, issued June 4, 1968 on application Ser. No. 549,849, filed May 1, 1966 there are disclosed methods and apparatuses of the character with which the present invention is concerned, capable of producing continuous fusion reactions. Generally speaking the apparatuses of these prior patents utilize a spherical geometry in which two generally spherical electrodes, one a cathode and the other an anode, are concentrically positioned with one inside the other. The cathode is electron-emissive in one embodiment of the aforesaid patents and is concentrically surrounded by a shell like anode. The cathode is permeable to the flow of ions, while the anode is not. In operation, an electrical discharge composed of high-order magnitude electron and ion currents in the space enveloped by the cathode produces a radial potential distribution which generally speaking, is a minimum

adjacent to the center of the cathode cavity and a maximum outwardly therefrom, the location off one such maximum being adjacent to the anode wall. Developed at a finite radius intermediate the center and the cathode wall is a "virtual anode" in the form of a spherical sheath. The potential of this virtual anode is essentially equal to that of the structural anode, thereby resulting in the entrapment of ions within the virtual anode sheath. By reason of electron emission from the cathode, the potential minimum, is formed at the center, which results in the trapped ions oscillating through the center. With a sufficiently high difference of potential between the virtual anode and the center, the trapped ions will be propelled at nuclear-reacting energies, so that ion collisions occurring at the center produce nuclear-fusion reactions.

The ions of the bipolar charges which are utilized for generating the aforesaid virtual electrodes as well as the fusion reactions in the apparatus of the aforesaid Farnsworth Pat. No. 3,258,402, are obtained in one instance by ionizing neutral gas introduced directly into the anode itself and in another instance by means of ion guns located on the outermost of the anode and cathode, these ion guns each producing a pencil-like, solid, cross-section beam which is aimed at the center of the device. In Farnsworth Pat. No. 3,386,883, application Ser. No. 549,849, mentioned hereinbefore, the source of the ions is generally confined to ion guns mounted on the exterior of the anode having a cathode thereinside. These ion guns also produce beams of concentrated, pencil-like configuration of solid cross-section.

Experimental evidence has shown that the more nearly radial the ion motions, the more efficient will be the utilization of the ions in producing fusion reactions. Ions not so reacting will represent a power loss. It has been found that space charge spreading in the pencil ion-beams mentioned hereinbefore produces a significant number of non-radial ions, thereby resulting in less than maximum utilization of the total number of injected ions and a reduction in ion-trapping efficiency.

SUMMARY OF THE INVENTION

In accordance with the broader aspects of this invention, there is provided an apparatus (sometimes referred to as a "fusor") for generating fusion reactions in which a spherical or cylindrical anode concentrically envelopes correspondingly shaped cathode and ion-source grid electrodes. The cathode encloses a volume free of tangible structure and centrally located with respect to the other electrodes. Both the cathode and ion-source grid are permeable to the flow of gas including positively charged particles. The ion-source grid is interposed between and spaced from the anode and cathode. Means are provided for applying potentials to the three electrodes which establishes a first electric field in the space between the anode and ion-source grid and a second electric field in the space between the grid and the cathode. These potentials are so applied that the ion-source grid is positive with respect to the anode. Also, the potentials applied are such that the second electric field is of sufficient magnitude to impart fusion-reacting energies to particles of positive charge introduced into the second space.

A sheath or shell-like cloud of electrons is caused to shroud the ion-source grid, this cloud being developed primarily by means of a thermionic cathode disposed in the space between the anode and the ion-source grid. Electrons from this thermionic cathode oscillate through the openings in the ion-source grid, thereby contributing to the formation of the aforesaid cloud. such that collisions of cloud electrons with neutral gas become imminent, resulting in the formation of ions inside the ion-source grid which are propelled toward the centrally located cathode by reason of the potential difference. These ions are essentially focused toward the center of the volume inside the cathode and interact via their space charge such that definite probability obtains for the collision of such ions at the center.

OBJECTS OF THE INVENTION

It is an object of this invention to provide apparatus for generating fusion reactions in which ions may be created in a substantially circular pattern of common radius about a center therewithin such that ion streams crossing at the center emanate substantially from all points on the circular pattern.

It is another object of this invention to provide an apparatus for producing fusion reactions in which an ion-source electrode is provide for developing an area source of ions which encircles a center toward which the ions are directed for producing fusion reactions.

BRIEF DESCRIPTION OF THE DRAWINGS

The above-mentioned and other features and objects of this invention and the manner of attaining them will become more apparent and the invention itself will be best understood by reference to the following description of an embodiment of the invention taken in conjunction with the accompanying drawing, wherein:

FIG. 1 is a diagrammatic illustration of a conceptual embodiment of the present invention used in explaining the operation thereof;

FIG. 2 is a potential distribution curve used in explaining the operation;

FIG. 3 is a side view, partly sectioned for clarity of this invention;

FIG. 4 is a similar view of a second embodiment of this invention;

FIG. 5 is a cross-section taken substantially along the section line 5--5 of the embodiment of FIG. 4;

FIG. 6 is an end view of the embodiment of FIG. 4; and

FIG. 7 is a diagrammatic illustration of the arrangement of FIG. 4 used in explaining the operation thereof.

DESCRIPTION

Involved in this invention is a non-magnetic method for the confinement of ionized fusion gases and the utilization of this phenomenon for the construction of a controlled nuclear-fusion reactor diagrammatically illustrated in FIG. 1. An ion-permeable circular cathode 20 is concentrically surrounded by a circular anode 21 and an ion-source grid 22 interposed therebetween. The grid 22 as well as the cathode 20 have a high degree of openness to accommodate therethrough the free flow of gas and charged particles. The grid 22 may be hypothetically considered as uniformly emitting ions over the entire circumference thereof in practical embodiments of this invention, the shapes of these electrodes may be spherical, cylindrical or toroidal, as will appear from the description that later follows.

With perfectly radial motions, ions from the grid 22 will be accelerated into the cathode 20, where mutual repulsion therebetween will cause them to be decelerated and brought to rest at some finite radius indicated by the numeral 23. They will then be accelerated radially outwardly. After passing through the cathode 20, they will again be brought to rest at the grid 22. Since ions are born at a location radially outwardly from the circle 23, concentration of ions at that circle 23 can be referred to as a virtual anode.

More particularly, FIG. 1 illustrates a hermetically sealed spherical electron-tube structure in which the cathode 20, may be considered as an open-mesh electrode formed of metallic screens or the like. The anode 21 may be considered as a solid metallic shell impervious to the flow of gas. The grid 22 may be considered as being of the same construction as the cathode 20. Suitable electrical connections are made to the electrodes 20, 21 and 22, a lead 24 being connected to the anode 21 for applying a positive potential thereto from power source 26, another lead 25 to the cathode 20 for connection to the negative terminal of the power source 26 and still another lead 27 to the grid 22 for applying a slightly higher positive potential thereto than that on the anode 21, this slightly higher potential being provided by a power supply 28. In the preferred embodiment of this invention, the anode 21 is grounded. A thermionic cathode 29 preferably annular in shape as shown is fixedly positioned in the space between the anode 21 and grid 22, such that electrons therefrom will flow toward the grid 22 rather than to the anode 21. The cathode 29 is grounded and otherwise has a filament supply voltage (not shown) connected thereto.

Ignoring for the moment the affect which the cathode 29 has upon the operation of the device, a neutral gas at low pressure inside the grid 22 is ionized. There develops, then, an electrical discharge composed of high magnitude electron and ion currents in the volume inside the cathode 20, which results in the development of a difference of potential which may be controlled so as to be a minimum near the geometric center 30 and a maximum adjacent to the grid 22, with one or more potential maxima (virtual anodes) and minima (virtual cathodes) concentrically enclosed within the cathode 20. Energetic ions falling inwardly toward the center 30 from regions of high potentials, will be propelled at velocities (energies) which are sufficient to produce nuclear-fusion reactions.

Ions born generally and uniformly adjacent to the inner surface of the grid 22 are indicated by the numeral 31 as following the radial paths of the respective arrows 32 to the inner boundary of the virtual anode indicated by the circle 23. This circle 23 is concentric with respect to the center 30 and indicates the size and location of the virtual anode.

Electrons in the device created in a region radially outside the virtual anode 23 will be accelerated toward the latter, passing through it toward the center 30. Once inside the virtual anode 23 mutual repulsion therebetween will decelerate them until they produce a negative space charge at some smaller radius, indicated by the circle 34 which represents a virtual cathode of spherical shape concentric about the center 30. Ions from the virtual anode 23 then will be accelerated inwardly toward this virtual cathode 34. By proper adjustment of the relative ion and electron currents, this virtual cathode 34 can be maintained at such a small radius that it can be regarded as being located almost at the exact center 30. The ions 31 traveling through this center region will possess high kinetic energies. Many of these ions will collide in this central region producing fusion reactions.

The reason for forming the virtual electrodes 23 and 34 is the attainment of particle trapping or confinement at high density by forced charge separation in spherical geometry. Formation of the virtual electrodes obviously consumes power, and the bipolar charges are the instruments used in the virtual electrode formation. The more efficiently these instruments are used, the less the power consumed. This invention is directly concerned with

these efficiencies and the provision of an area source of ions which spherically encompasses the bipolar configuration in the center.

The ideal structure is diagrammatically shown in FIG.1 in which the ion-source grid 22 is considered as the area source of the ions 31, which emanate from the entire spherical surface thereof. The ions are considered as following precisely radial paths such that upon encountering the virtual anode 23 they return to the grid 22 along the same paths. Each ion therefore contributes all of its energy to the formation and retention of the virtual anode 23, such that the ions 31 considered as instrumentalities are utilized with maximum efficiency. In contrast, non-radial movements of the ions 31 will result in less than maximum efficiency in the utilization of the ions in the formation of the virtual anode 23 and any structure or forces which contribute to these non-radial movements constitute deficiencies which should be remedied. Non-radial space charge spreading between adjacent ions has in prior art devices produced these non-radial components. In the present invention, this space charge spreading is substantially eliminated by the use of the spherically shaped ion-source grid 22, which may be considered as an area source of ions from which ions emanate over the entire spherical surface thereof. Ions in their radial motions thereby experience the same or substantially the same transverse force components from adjacent ions, these components acting in opposite directions, thereby substantially nullifying each other. The resultant ion motion therefore is substantially solely radial.

In the following will be described at least two different practical working embodiments of this invention, whereby the ideal conditions of ion input may be approached, thereby resulting in greater efficiencies in fusor operation.

Continuing with the embodiment of FIG. 1, potentials are applied to the various electrodes 20, 21 and 22 in accordance with the potential distribution illustrated by the graph of FIG. 2. With the anode 21 hermetically sealed and containing fusion reacting gas, such as deuterium or deuterium-tritium, at a pressure of the order of 10^{-5} torr, electrons from the cathode 29 will be attracted toward and through the ion-source grid 22, which is more positive than the anode 21. Those electrons which are not collected by the grid 22, pass through the openings thereof into the space therein where they encounter the more negative potential of the cathode 20. This results in the electrons being turned backwardly toward the grid 22, where once again most of them penetrate the openings thereof and pass beyond. Upon passing through, they immediately encounter the attraction of the grid 22, such that they return once again toward the grid 22, passing through the openings therein if they are not collected. As will now be appreciated, the electrons in many cases make repeated oscillatory passes through the meshes of the grid 22 before they are eventually collected. Representative paths followed by these electrons are indicated by the serpentine dashed lines 35; which tend to fill in the entire spherical extent of the grid 22. These electrons as well as those produced in the process of ionization and those produced by secondary processes on anodes 21 result in the formation of an electron cloud in sheath or shell-like form which clothes or otherwise submerges the grid 22. Neutral gas within the vicinity of this cloud is ionized by the electrons therein, thereby producing the ions 31 previously described.

Ions impacting the cathode 20 will produce secondary electrons which fall outwardly toward the more positive potential of the grid 22. These electrons, if not collected by the grid 22, pass through the openings thereof and impact the anode 21, once again releasing secondaries which are attracted back toward the grid 22. These electrons contribute to the formation of the cloud at the grid 22 and ionization previously explained.

Since the electron cloud is also spherical in shape as is the grid 22, ionization will occur throughout this spherical extent. The ions 31 may thereupon be regarded as emanating from an area source of spherical shape rather than from a point source as is true in certain prior art devices.

A working embodiment of the arrangement just described in connection with FIG. 1 is shown in FIG. 3. in which the anode is a stainless steel shell and the cathode 20 and grid 22 are in the form of self-supporting cages made of tantalum or the like wire arranged like latitudes and longitudes on a sphere. The intersections of the wires are spot-welded so as to make each shell or cage 20 and 22 self-supporting and rigid. The openings in the cages are large, in one instance being about one-fifth the diameter of the respective cage. The grid 22 is fixedly positioned concentrically inside the anode 21 by means of a conductive supporting bar 36 which is held in place by means of a feed-through insulator 37 secured to an opening 38 in the anode 21. This supporting bar 36 constitutes the electrical connection to the grid 22.

A similar supporting bar 39 is secured to the cathode 20 and is rigidly secured in place by means of another feed-through insulator 40 rigidly secured to the anode 21, this bar 39 passing through an opening 41 in the anode. The grid 22 has an opening 42 in the upper end thereof through which the bar 39 passes, the size of this opening 42

being such as to provide adequate insulation against accidental arcing between the bar 39 and the grid 22 due to the high voltages applied thereto.

The annular, thermionic cathode 29 is fixedly mounted in the illustrated position by means of the supporting straps 43 secured in place with respect to the anode 21. The bar 43a enclosed in the feed-through insulator 44 constitutes one connection to the heater inside the cathode 29, the other connection to the heater being grounded to the anode, 21 shell. The cathode 29 is concentricly positioned with respect to both the grid 22 and the anode 21 as shown. To an opening in the bottom of the shell 21 is secured a tubular connection 45 to which may be connected a vacuum pump for scavenging unwanted gases from the interior of the anode 21. The latter is hermetically sealed.

In the operation of this embodiment of FIG. 3, the anode 21 is evacuated and controlled amounts of fusion gases are admitted thereto until desired pressures are reached. By way of example, gas pressures in the vicinity of 10^{-3} to 10^{-4} torr have been found to provide an operative device. Typical operating voltages applied to the various electrodes are indicated in FIGS. 1 and 2. Adjustment of the voltage applied to the grid 22 and adjustment of the gas pressure determines in large measure the magnitude of the ion current to the cathode 20.

In FIGS. 4 through 7 are illustrated a second embodiment of this invention which is primarily cylindrical rather than spherical as is true of the arrangement of FIG. 3. Like numerals with the suffix letter a will indicate like parts. The cathode 20a and ion-source 22a are cylindrical and formed of wire with substantial spacing therebetween. The structure thereof will appear essentially the same as that of the spheres 20 and 22 in FIG. 3.

The opposite ends of the cathode 20a and grid 22a are formed as hemispheres as shown so as to maintain equal spacing and shapes between the two electrodes around the entire peripheries thereof.

The anode 21a is generally a cylindrical shell of stainless steel or the like having a vacuum pump connection 45a at the bottom thereof and cap assemblies 46 on the opposite ends which serve to seal hermetically the anode 21a and provide for mounting the various internal

electrodes as will be described. The cathode 20a is fixedly held in position by means of a supporting bar 39a of a feed-through insulator 40a. The bar 39a passes through an insulating opening 42a in the ion-source grid 22a as shown. A metal disc 47 is secured to the anode shell 21a inside the opening 41a for substantially closing the same with the exception of the provision of an insulating opening 48 surrounding the supporting bar 39a.

The ion-source grid 22a is supported at both ends by means of feed-through insulators 49 having insulator portions secured to the cap assemblies 46 and conductive supporting bars 50 secured to the grid 22a by means of welding or the like as shown. The mountings for this grid 22a are rigid so as to maintain the proper positioning of the grid with respect to the anode and cathode.

In the opposite ends of the anode 21a are provided two metallic end bells or hemispheres 51 equally spaced from and substantially concentric with respect to the ends of the cathode 20a and grid 22a. Each hemisphere 51 forms a part of the anode 21a and is held in position by means of a short length of metal tubing 52 secured at one end to the hemisphere 51 and at the other end to the cap assembly 46 as shown. The central portion of the hemisphere 51 is provided with an aperture 53 through which the interior of the fusor may be viewed.

Extending coaxially from each cap assembly 46 is a viewing-tube assembly 54 closed by a Brewster angle window for diagnostic studies. It will be understood that all of these parts are fitted together so as to hermetically seal the device such that the interior of the anode 21a can be evacuated and the pressure therein controlled.

The bars 50, which mount the grid 22a are insulated from the respective hemispheres 51 by means of ceramic sleeves 56.

Inside each hemisphere 51 is mounted a thermionic cathode 29a, this cathode being a part of an assembly composed of an annular mounting plate 58 spot-welded to the respective hemisphere 51 in coaxial relation therewith. To the inner edge of the plate 58 is secured a short focusing cylinder 59 and mounted on the plate 58 is the annular cathode 29a of conventional design which contains an electrical heater having leads to which is connected the filament supply. As explained earlier and as shown diagrammatically in FIG. 5, one of these leads

is grounded to the anode 21a while the other lead penetrates the anode 21a via a feed-through insulator for connection to the other side of the filament supply. As shown, the filament 29a is fastened to the mounting plate 58 by means of suitable metallic posts 60.

The operation of the arrangement of FIG. 4 is best explained by referring to FIG. 7. With the interior of the hermetically sealed anode 21a properly evacuated and a suitable quantity of fusion gas therein, electrons from the cathodes 29a follow serpentine paths through the meshes of the grid 22a, thereby contributing to ionization of neutral gas and the eventual formation of the electron cloud which shrouds the grid 22a as explained. Ions 31a follow the radial paths 32a toward the center of the device, which in this case is the axis 30a. In cross-section, this arrangement of FIG. 7 will appear exactly like that shown in FIG. 1; however, in longitudinal section, the ions 31a will follow essentially parallel paths which define planes normal to the axis of 30a. Those ions formed in the curved ends of the device will also be focused inwardly toward the axis 30a but at angles to the planes just described.

Inasmuch its all ions are directed toward a crossover on the axis 30a, certain of such ions will collide, producing fusion reactions. Both the anode and grid voltages may be adjusted to secure optimum operation.

A third embodiment of this invention essentially the same as that of FIG. 4 is of an annular or toroidal shape, the anode 21a being formed into a circle or doughnut shape in which the ends 46 merge. In this embodiment, the anode 21a would appear as a doughnut having a hollow annular interior, the cathode 20a and the grid 22a having similar shape therein. In this case, there would be no closed ends on any of these electrodes; however, in cross-section the structure would appear almost exactly as shown in FIG. 1. In this geometry, the cathodes 29a would be located adjacent to anode 21a but outside of anode 22a. The operation would be essentially the same as already described.

In a working embodiment of this invention as shown in FIG. 3 various of the components are of the following dimensions, these being given by way of example only since such dimensions may be changed without departing from the concept of this invention

Anode 21 diameter 6"

Ion cage 22 diameter 4 1/2"

Cathode 20 diameter 1 1/2"

While there have been described above the principles of this invention in connection with specific apparatus, it is to be clearly understood that this description is made only by way of example and not as a limitation to the scope of the invention.

What is claimed is:

1. Apparatus for generating fusion reactions comprising anode means, cathode means inside said anode means, ion-source means spaced from and disposed between said anode and cathode means, said cathode means defining a volume centrally located with respect to all of said anode, ion-source and cathode means, said volume being free of tangible structure, means for applying potentials to said anode, ion-source and cathode means for establishing a first electric field in the first space between said anode and ion-source means and a second electric field in the second space between said ion-source and said cathode means, said ion-source means being of positive potential with respect to said anode and cathode means said second electric field being of sufficient magnitude to impart fusion-reacting energies to particles of positive charge introduced into said second space, both said ion-source and cathode means being permeable to charged particle and gas flow, means providing electrons in said second space adjacent to said ion-source means which ionizes neutral gas therein, means

including said anode, ion-source and cathode means for focusing ions inside said ion-source means toward the center of said volume, and means for introducing into and controlling amounts of gas into said first space.

2. The apparatus of claim 1 in which said anode, said ion-source and cathode means are of circular shape in cross-section and concentrically positioned with respect to each other.

3. The apparatus of claim 2 in which said anode means is essentially solid hermetically sealed metallic shell, and each of said ion-source means and said cathode means is a self supporting conductive electrode having a multiplicity of openings therein through which gas and ions may freely flow.

4. The apparatus of claim 3 in which said electron means is a thermionic cathode disposed in said first space adjacent to said ion-source electrode, whereby electrons emitted by said thermionic cathode are attracted toward said ion-source electrode instead of said anode shell.

5. The apparatus of claim 4 in which said anode shell and said electrodes are spherically shaped, said thermionic cathode is of annular shape and concentrically disposed about a diameter of said anode shell, said thermionic cathode having two supply leads of which one is grounded to said anode shell and the other passes through the latter in hermetically sealed insulated relation.

6. The apparatus of claim 5 in which said electrodes are each fabricated of wire spaced apart and interconnected so as to provide a foraminous structure in which the openings have dimensions about one-fifth the diameter of the particular electrode, said anode shell having a vacuum pump connection by means of which the anode shell can be evacuated and controlled quantities of gas can be admitted thereto.

7. The apparatus of claim 4 in which said anode shell and said electrodes are cylindrically shaped, the opposite ends of each of said anode shell and said electrodes being hemispherically shaped, there being two such thermionic cathodes which are of annular shape, these cathodes being coaxial with respect to the axis of said anode shell with one at each end of said ion-source electrode.

8. The apparatus of claim 7 in which said electrodes are each fabricated of wires spaced apart and interconnected so as to provide a foraminous structure, and means for focusing electrons emitted by said thermionic cathodes toward said ion-source electrode in the portion thereof which is cylindrical

9. The apparatus of claim 8 in which the length of the diameter of said thermionic cathodes is between the lengths of the diameters of said ion-source and cathode electrodes, said focusing means including a focusing cylinder disposed coaxially inside each thermionic cathode.

References Cited

UNITED STATES PATENTS

3,258,402 6/1966 Farnsworth 176-1

3,386,883 6/1968 Farnsworth 176-1

Patent Drawings

FIG. 1

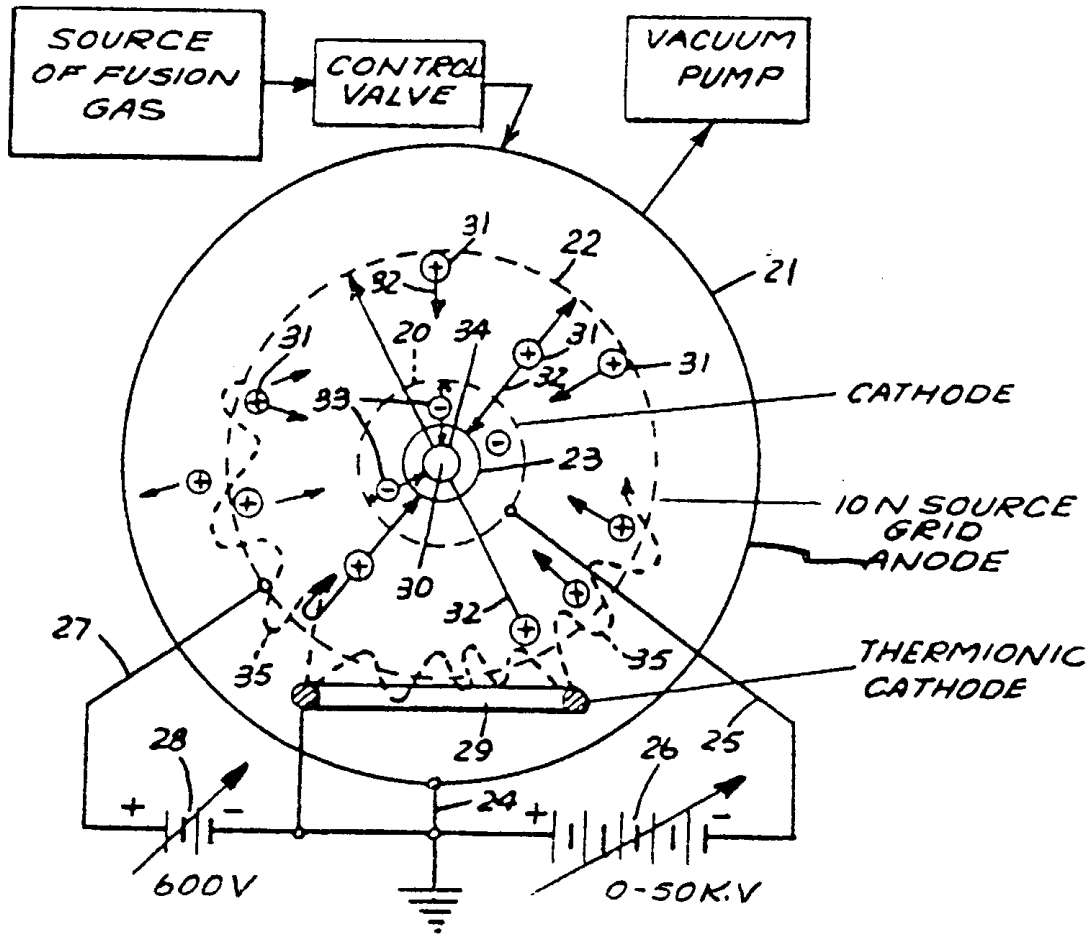

FIG. 1 is a diagrammatic illustration of a conceptual embodiment of the present invention used in explaining the operation thereof;

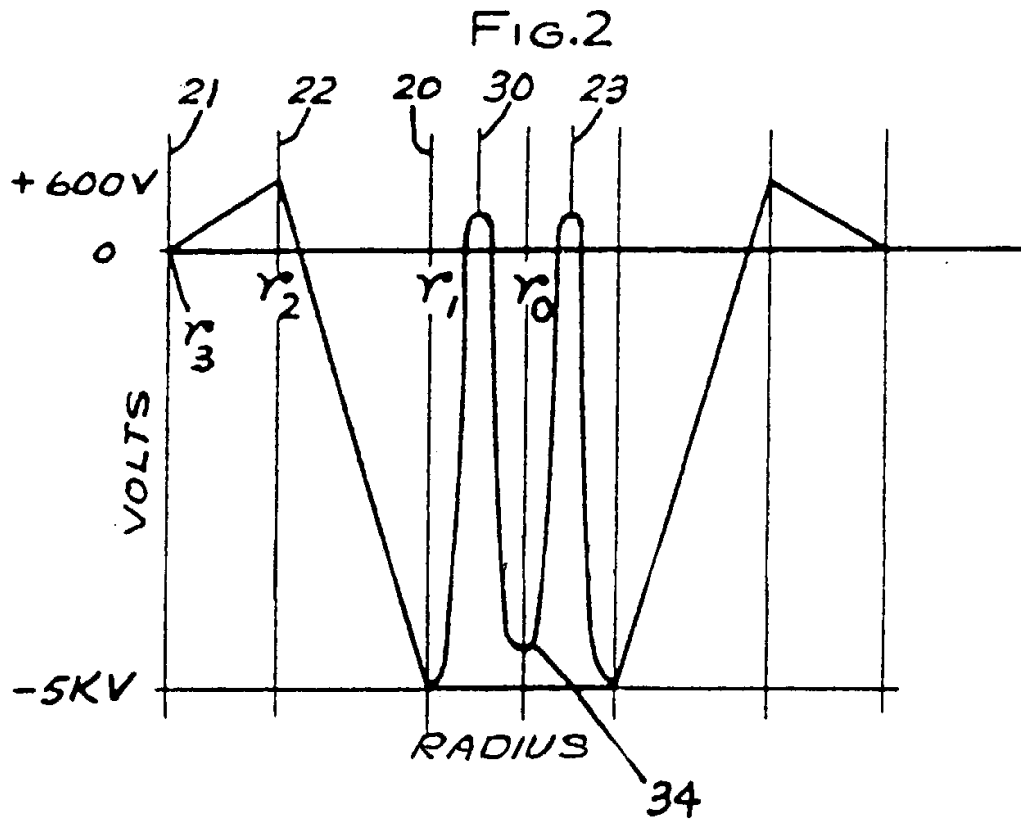

FIG. 2 is a potential distribution curve used in explaining the operation;

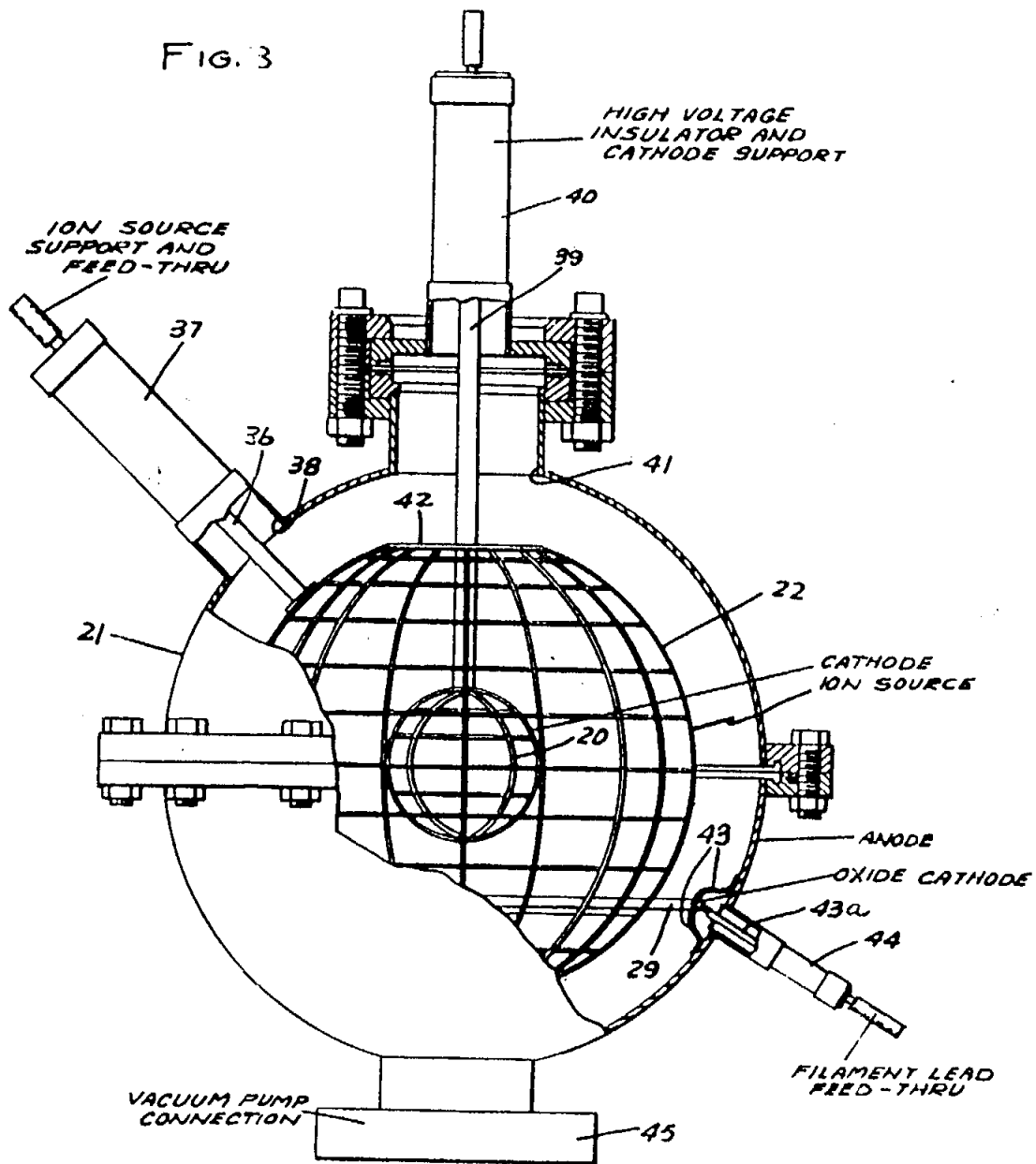

FIG. 3 is a side view, partly sectioned for clarity of this invention;

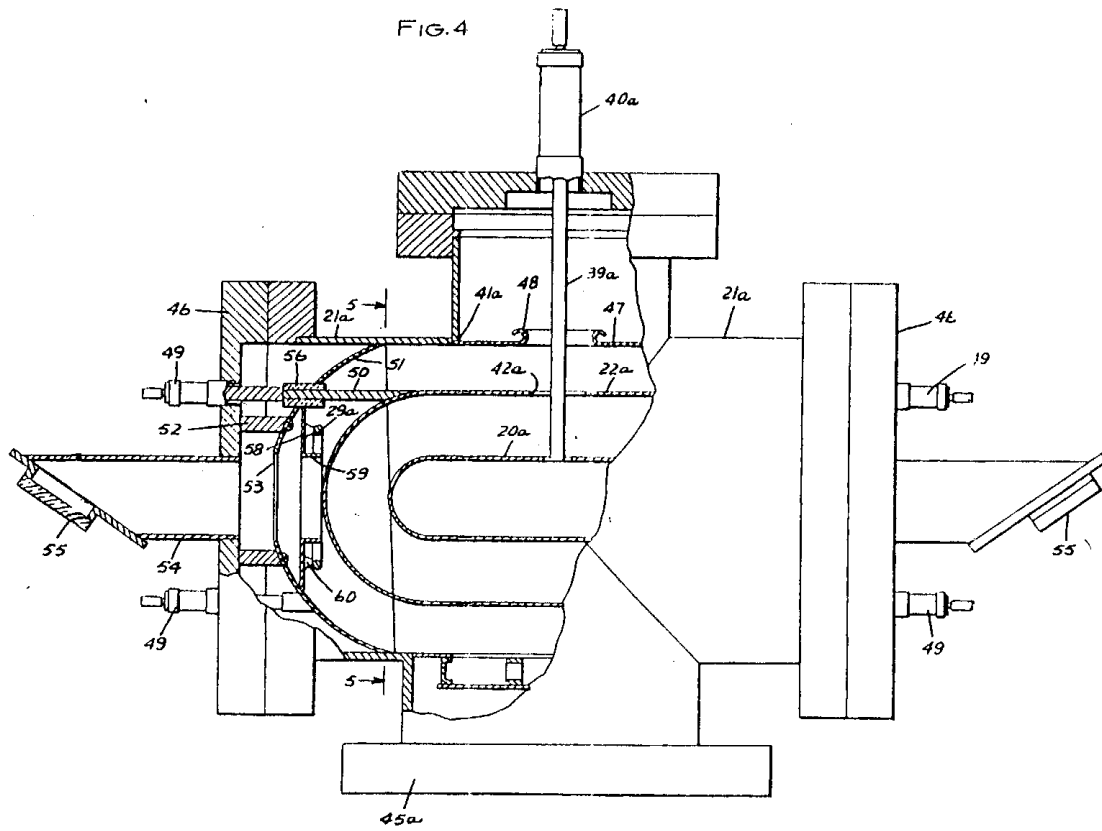

FIG. 4 is a similar view of a second embodiment of this invention;

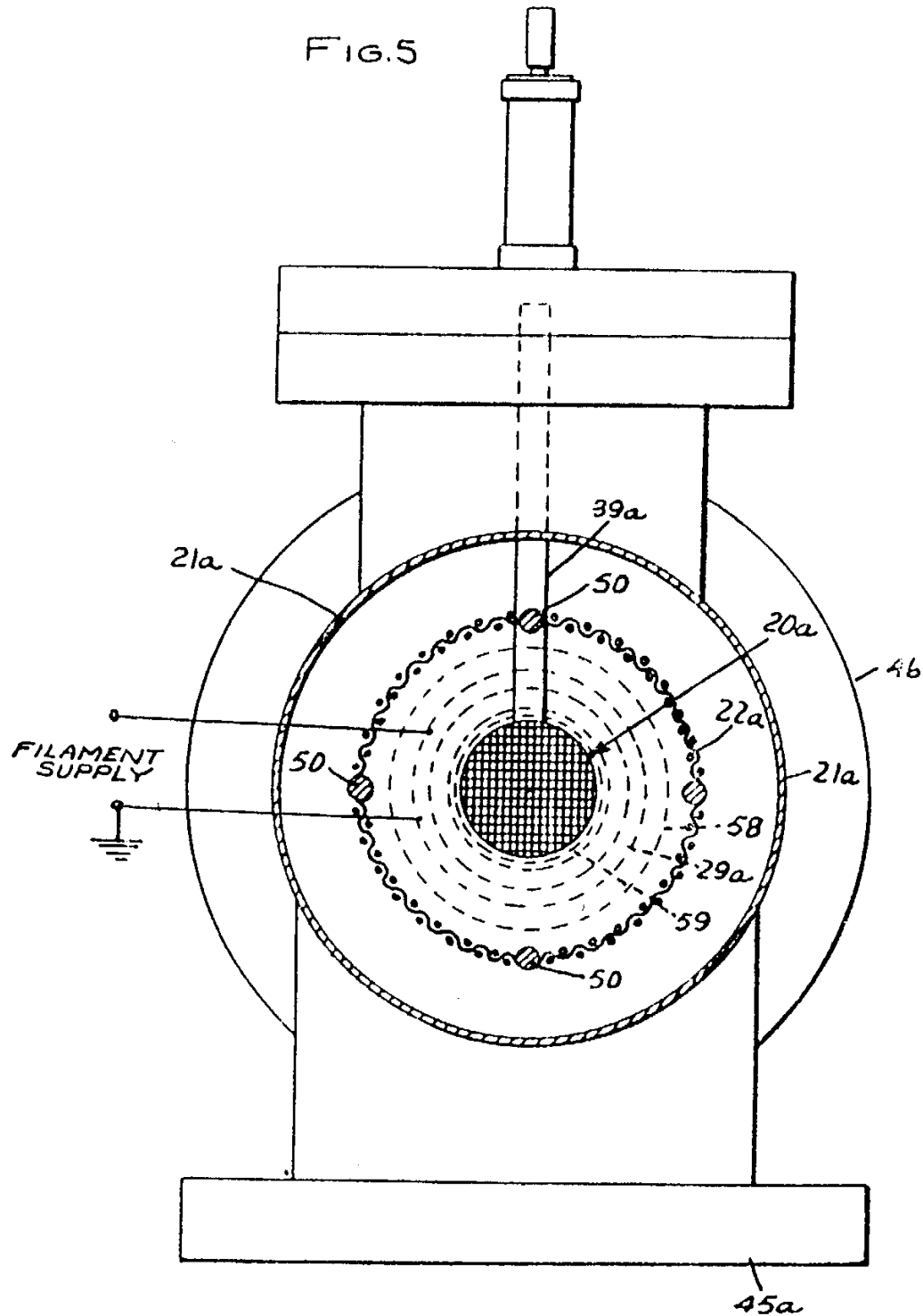

FIG. 5 is a cross-section taken substantially along the section line 5--5 of the embodiment of FIG. 4;

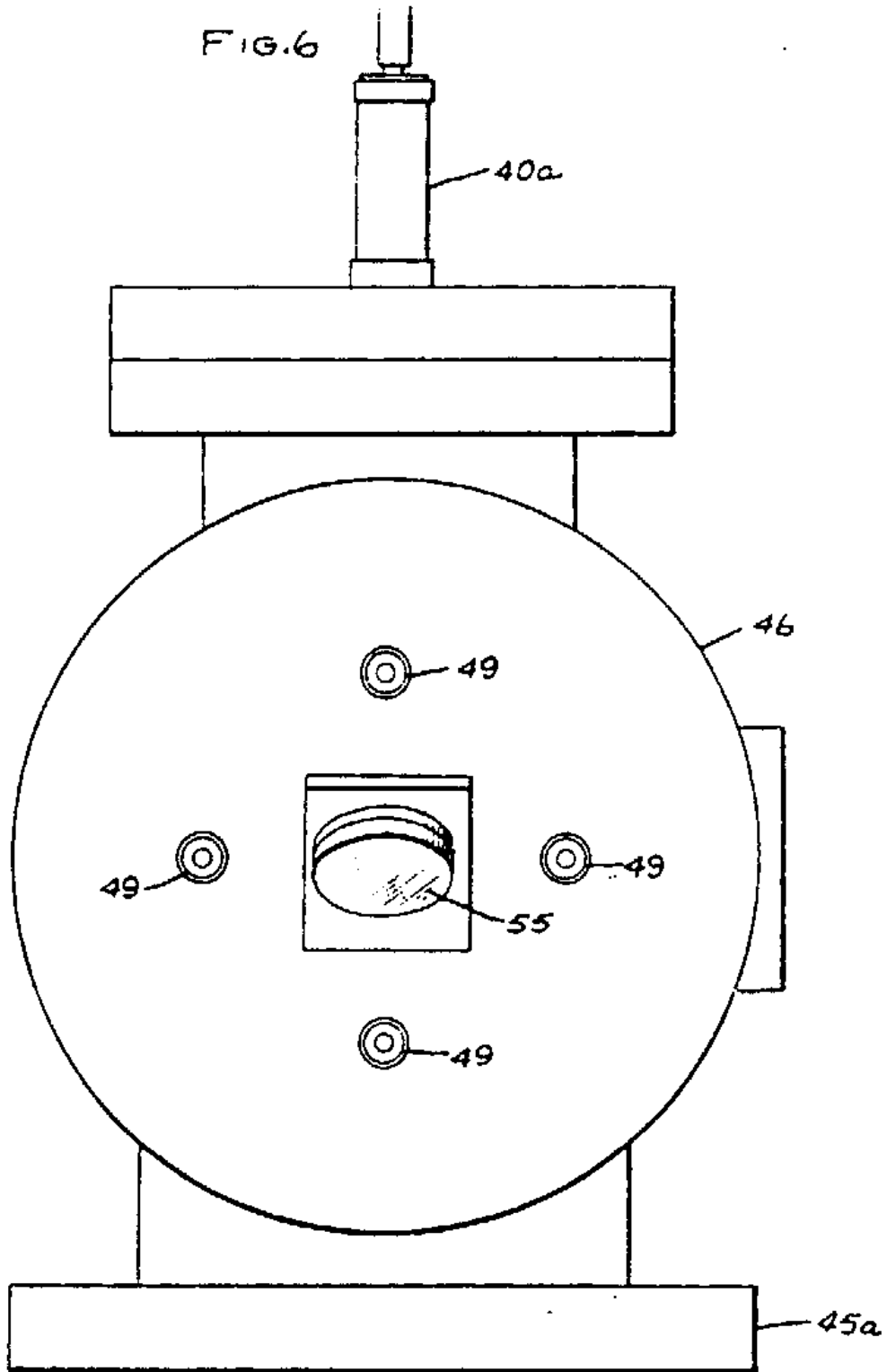

FIG. 6 is an end view of the embodiment of FIG. 4; and

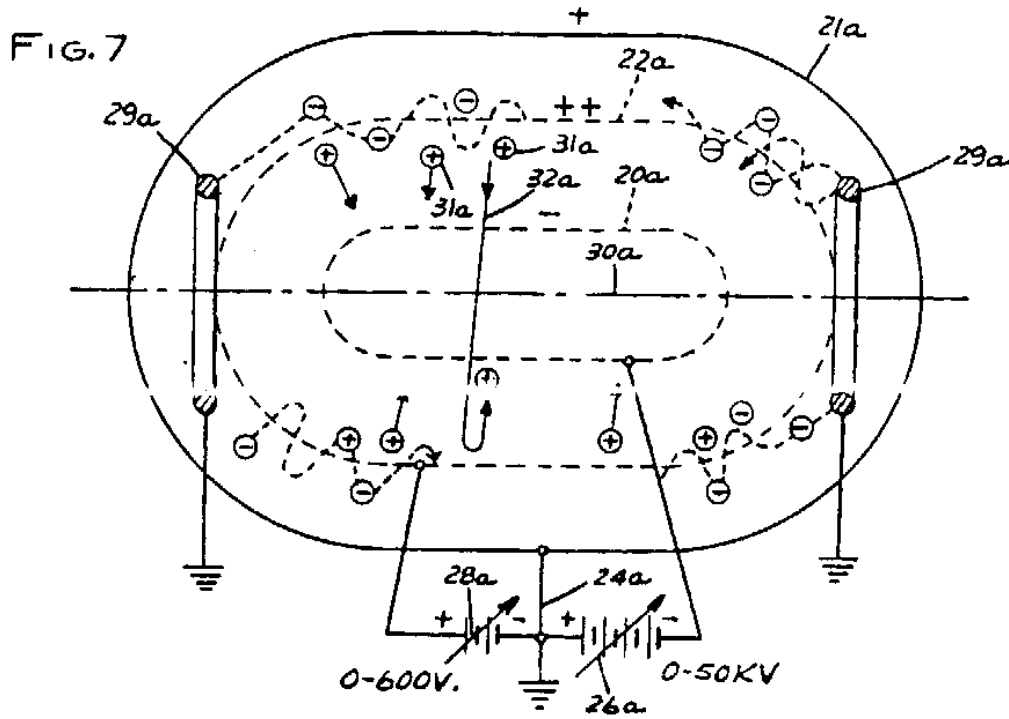

FIG. 7 is a diagrammatic illustration of the arrangement of FIG. 4 used in explaining the operation thereof.

Links